

INSTALLATION INSTRUCTIONS ADAPTER COUPLING

P/N 9942-00-0135-00

IMPORTANT

For use on:
Polyethylene (PE) gas pipe meeting
the requirements of ASTM D 2513

Pressure Rating: Designed to meet or
exceed pressure rating of PE pipe per
49 CFR Part 192 and ASTM D 2513

Operating Temperature: -20 to 140° F

Material: Carbon Steel

THREADED END

1. APPLY A GOOD GRADE OF THREAD SEALANT OR LUBRICANT TO THREADS.
2. TIGHTEN JOINT LEAK TIGHT.

PE COMPRESSION END

3. CUT PE PIPE ENDS SQUARE, DEBURR INSIDE AND OUTSIDE, CLEAN THOROUGHLY TO ASSURE THERE IS NO DIRT, GREASE, OIL, ETC. ON ASSEMBLY AREA OF PIPE.
4. MARK STAB LENGTH ON PE PIPE.

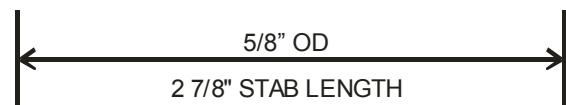

5. LOOSEN COMPRESSION NUT AND INSERT PE PIPE UNTIL IT BOTTOMS IN COUPLING.
6. TIGHTEN COMPRESSION NUT UNTIL IS SHOULDERS AGAINST THE COUPLING. LINE MARKED FOR STAB LENGTH SHOULD BE NO MORE THAN 7/16" FROM FACE OF NUT, IF NOT, REASSEMBLE.
7. TO ASSURE PROPER ASSEMBLY AND TO COMPLY WITH 49 CFR 192 SUBPART J—TEST REQUIREMENTS, THE JOINT SHALL BE LEAK TESTED.

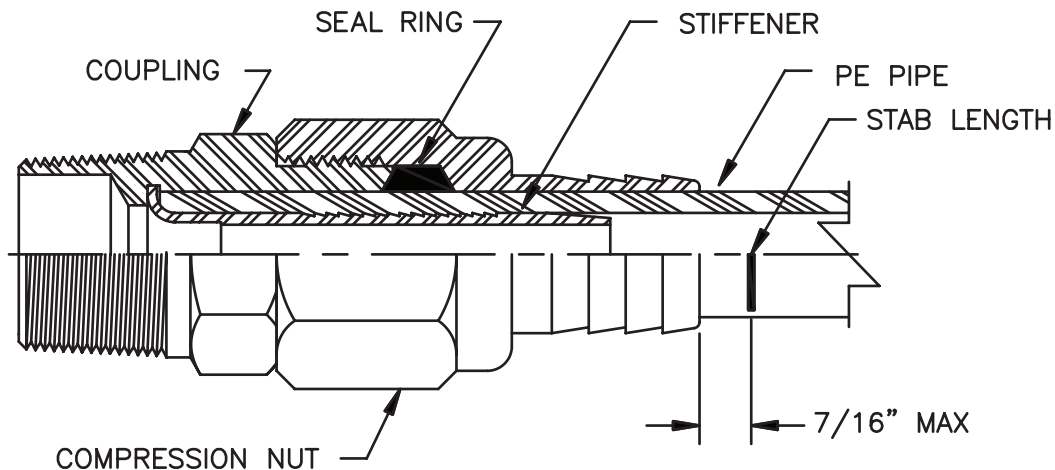

ECN 2625 REV "E" 08/25/14